

REV	ECN/ERN NO.	DRWN	CHKD	APPD
C	ECN 2601	JOSE 3/17/03	DJW 4/2/03	TBT 4/11/03

PRESSURE DATA
 DESIGN SUPPLY PRESSURE (PI, PO)-10,000 PSI
 PROOF SUPPLY PRESSURE (PI, PO)-15,000 PSI
 DESIGN PILOT PRESSURE (PPO)-150 PSI
 MINIMUM PILOT PRESSURE 80 PSI

FLOW DATA
 Cv=5
 FLUIDS- WATER, MINERAL OIL BASED
 HYDRAULIC FLUIDS

PORTS
 SUPPLY IN- (PI) .63
 SUPPLY OUT- (PO) .63
 PILOT PRESSURE OPEN (PPO) 1/4 NPT
 VENT PORT- (V) .63

GENERAL DATA
 TEMP RANGE -20°F TO 150°F
 APPROX WEIGHT-31 LBS
 FIELD SERVICEABLE

MATERIALS
 17-4 PH (NACE)
 PEEK
 NITRONIC 60
 316 SS
 DELRIN AF
 NITRILE
 TEFLON

PATENT NO. 5771931 APPLIES

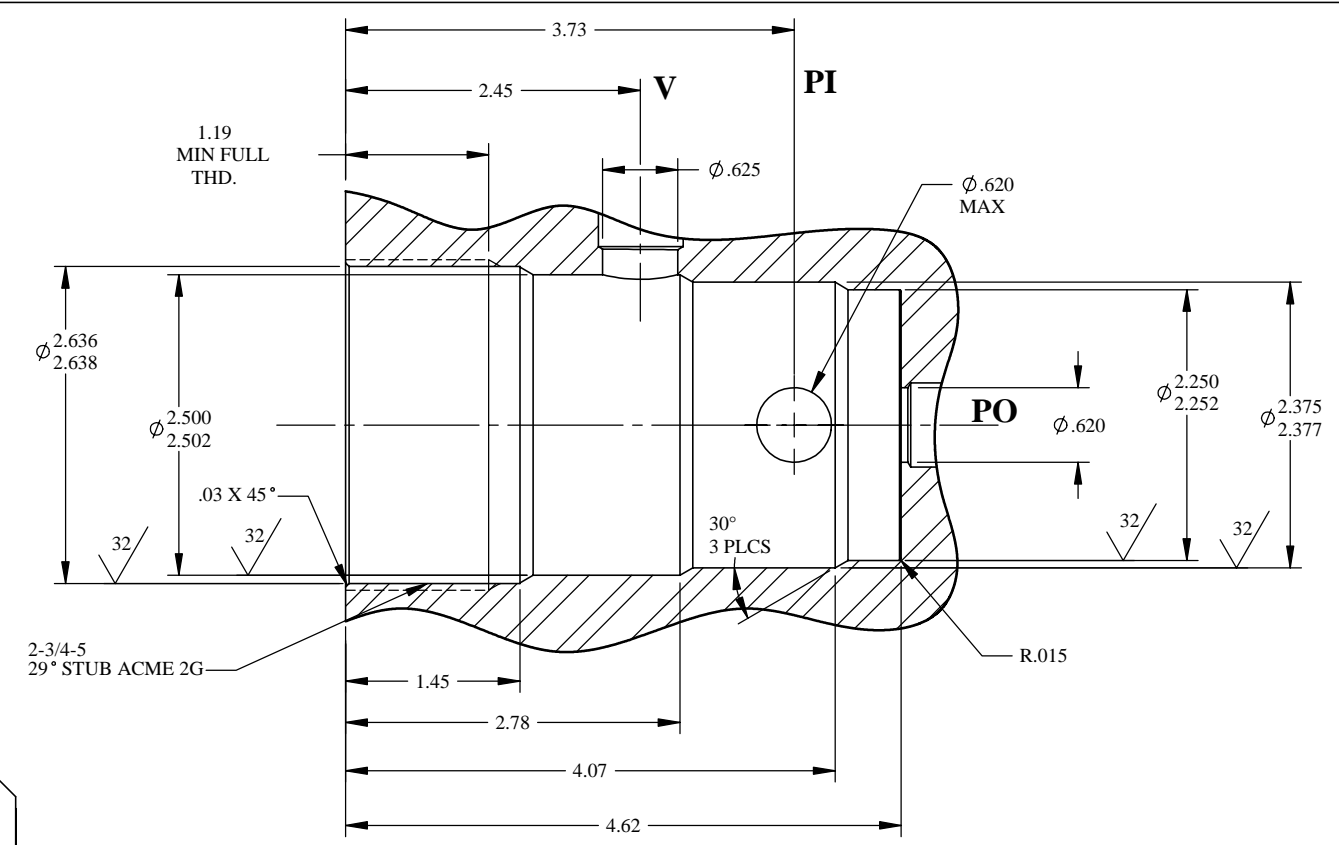

CAVITY DETAIL

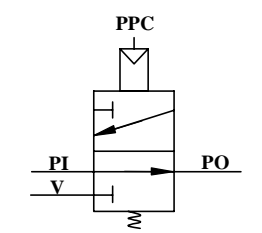
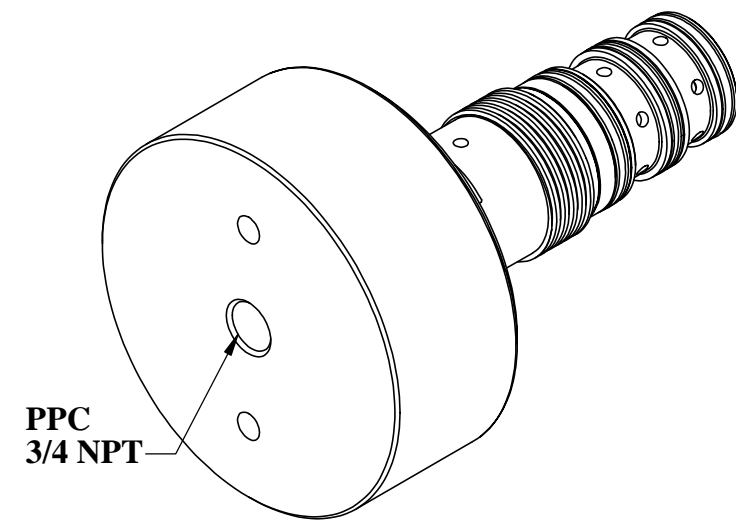
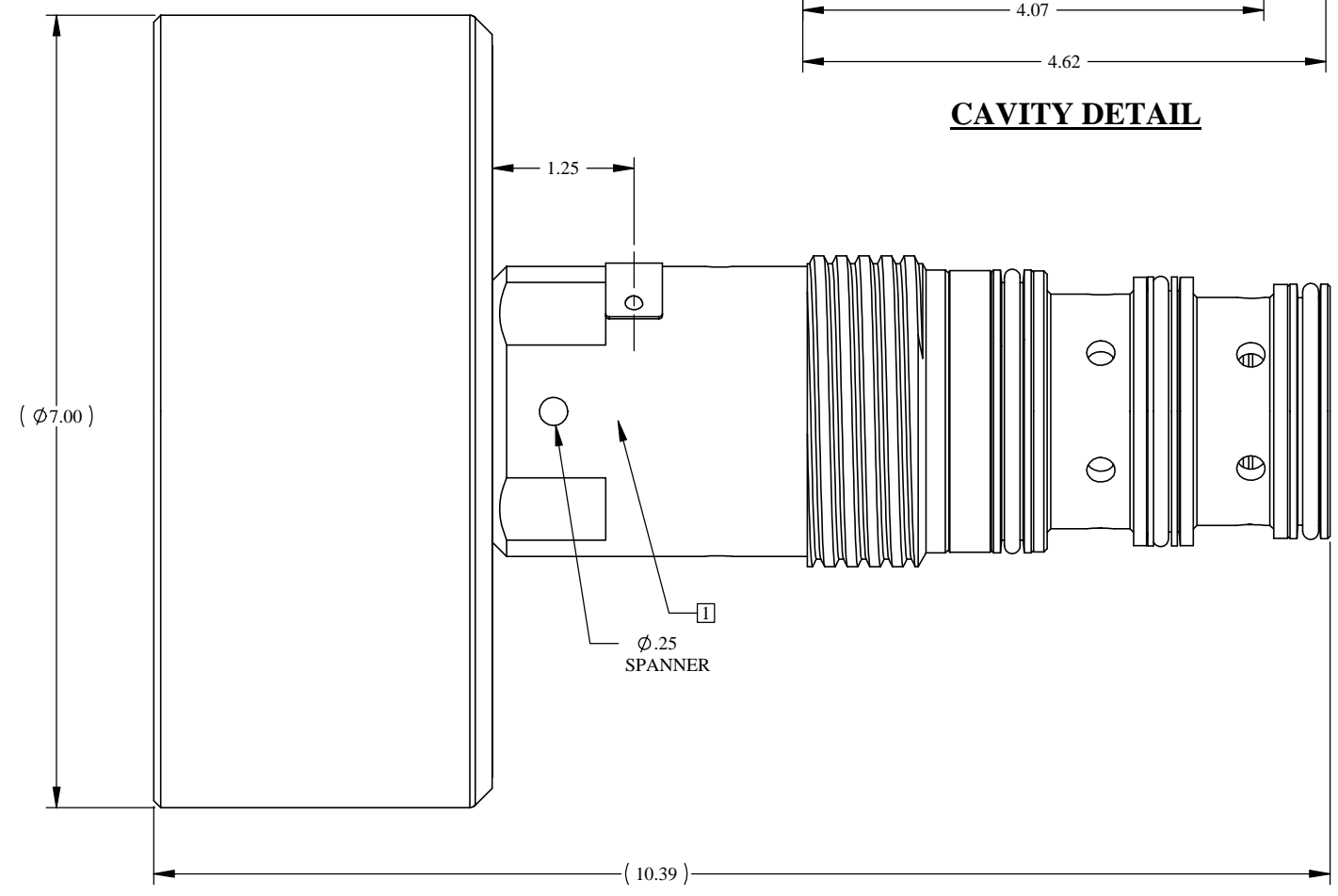

SCHEMATIC

3. OPTIONAL VALVE BLOCK 27394-XX REFER TO DASH NUMBERS FOR VARIOUS CONNECTION OPTION.
 2. FOR BOTTOM SEAL REMOVAL USE TOOL ATL 10010-001
 NOTES: [1] STAMP: ASSY PART NO., PATENT NO. PRESSURE RATING IN AREA INDICATED IN ACCORDANCE WITH GVC MANUFACTURING CUSTOM AND PRACTICE.

MATERIAL SEE INDIV BOM ITEMS	UNLESS OTHERWISE SPECIFIED TOLERANCES: DECIMALS FRACTIONS ANGLE X ± .1 ± 1/32 ± 1° XX ± .01 XXX ± .005 DEBURR BREAK SHARP EDGES .010 INTERNAL RADIUS .015 FINISH 68	DRWN BY WRC	DATE 1/7/03	GILMORE VALVE CO. 1231 LUMPKIN RD. HOUSTON, TX. 77043
TREATMENT	CONDITION	CHKD BY DJW	DATE 1/13/03	
PROC. NO.		APPD BY TBT	DATE 1/13/03	
THE INFORMATION CONTAINED IN THIS DRAWING IS THE SOLE PROPERTY OF GILMORE VALVE CO. UNLESS OTHERWISE STATED, ANY REPRODUCTION IN PART OR WHOLE WITHOUT THE WRITTEN PERMISSION OF GILMORE VALVE CO. IS PROHIBITED.		ERN NO. 00731	DATE 1/6/03	
DIMENSIONS ARE IN INCHES DO NOT SCALE DRAWING INTERPRET DIM. & TOL. PER ASME Y14.5M - 1994		SIZE C		DWG NO. 27501-2
SCALE NTS		SOLIDWORKS		REV C
		SHEET 1 OF 2		

REV	ECN/ERN NO.	DRWN	CHKD	APPD
C	ECN 2601	JOSE 3/17/03	DJW 4/2/03	TBT 4/11/03

ITEM NO.	QTY.	PART NO.	DESCRIPTION	RK	SK
1	1	27503	SPRING HOUSING		
2	1	27173	PISTON ROD		
3	1	27177	COMPRESSION SPRING		
4	1	27180	SPACER		
5	1	18100-153C	O-RING	X	X
6	1	18100-101C	O-RING	X	X
7	1	27176	SEAL, TOP	X	X
8	1	27182-2	SEAL SLEEVE	X	
9	2	27181	BACKUP RING	X	X
10	1	18100-104C	O-RING	X	X
11	1	27179	CAGE		
12	2	18110-216T	BACKUP RING	X	X
13	1	18100-147C	O-RING	X	X
14	1	21112-005	LOCK NUT, 3/8-24 UNF	X	
15	1	18100-102C	O-RING	X	X
17	1	27481-1	PILOT CYLINDER ASSEMBLY		
16	1	27174	SEAL, BOTTOM	X	X
18	1	27517	PILOT ROD		
20	2	21082-002	SCREW, DRIVE		
21	A/R	25822	ANTI SEIZE		
22	1	25822-1	ANTI SEIZE	X	X
19	1	12227	NAME TAG		

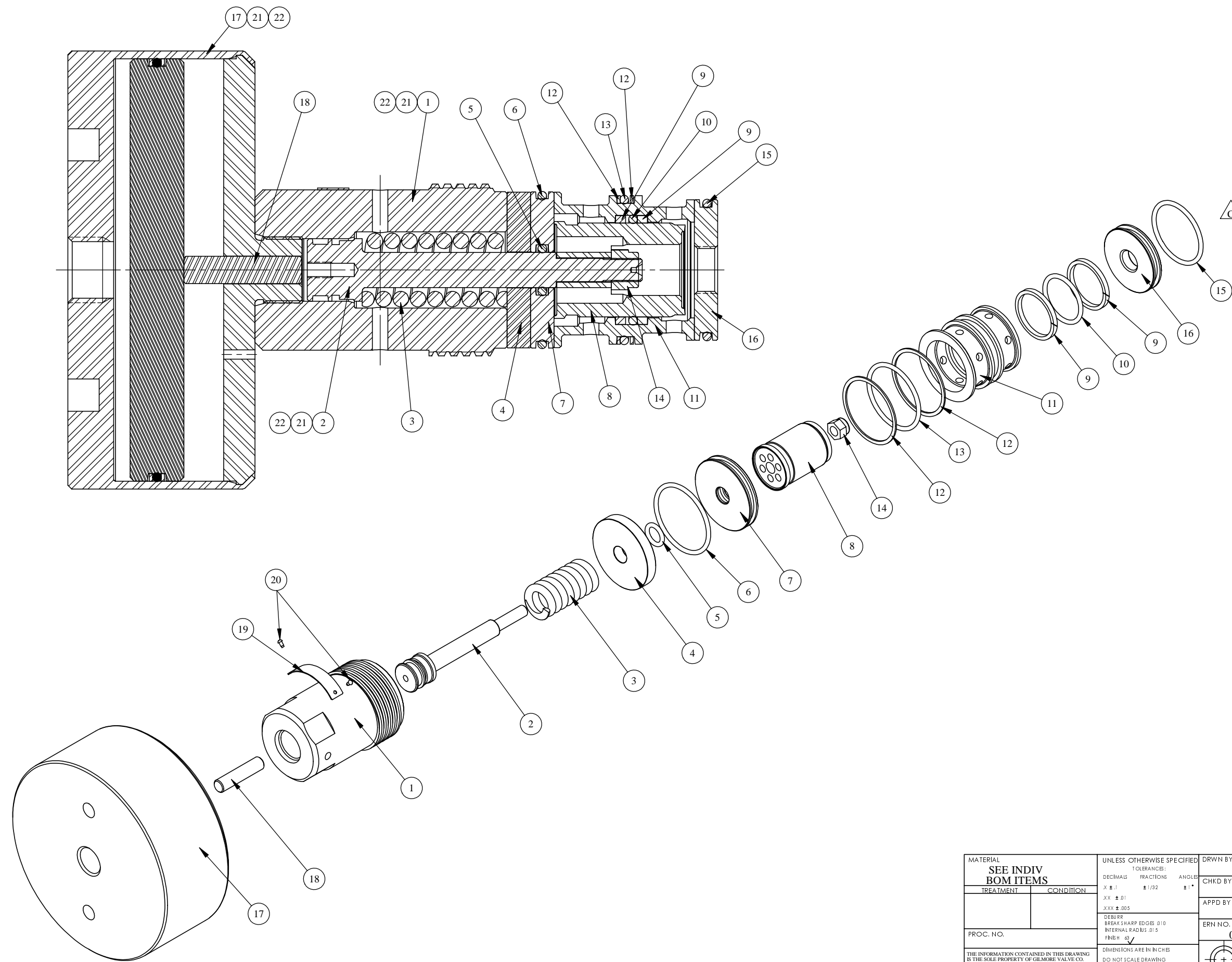

MATERIAL SEE INDIV BOM ITEMS		UNLESS OTHERWISE SPECIFIED TOLERANCES: DECIMALS FRACTIONS ANGLE X ± .1 ± 1/32 ± 1° XX ± .01 XXX ± .005 DEBURR BREAK SHARP EDGES .010 INTERNAL RADIUS .015 FINISH 68		DRWN BY WRC	DATE 1/7/03	GILMORE VALVE CO. 1231 LUMPKIN RD. HOUSTON, TX. 77043 VALVE, SPM ASSEMBLY 1/2" N.O., AIR PILOT 10,000 PSI
TREATMENT		CONDITION		CHKD BY DJW	DATE 1/13/03	
PROC. NO.				APPD BY TBT	DATE 1/13/03	
<small>THE INFORMATION CONTAINED IN THIS DRAWING IS THE SOLE PROPERTY OF GILMORE VALVE CO. UNLESS OTHERWISE STATED, ANY REPRODUCTION IN PART OR WHOLE WITHOUT THE WRITTEN PERMISSION OF GILMORE VALVE CO. IS PROHIBITED.</small>		<small>DIMENSIONS ARE IN INCHES DO NOT SCALE DRAWING INTERPRET DIM. & TOL. PER ASME Y14.5M - 1994</small>		ERN NO. 00731	DATE 1/6/03	SIZE C DWG NO. 27501-2 SCALE NTS SOLIDWORKS SHEET 2 OF 2