

REV	ECN/ERN NO.	DRWN	CHKD	APPD
A	ERN 00586	JOSE 2/19/02	WRC 2/22/02	TBT 2/25/02

ITEM NO.	QTY.	PART NO.	DESCRIPTION	RK	SK
1	1	22904-1	HOUSING PLUG		
2	1	22166-1	SPRING HOUSING		
3	1	12048	TOP SEAL	X	X
4	1	12047	VENT CAGE		
5	1	11487	UPPER CAGE		
6	1	11484	PISTON		
7	1	12726	LOWER CAGE		
8	1	23700-3	SPINDLE VALVE	X	
9	1	11485	BOTTOM SEAL	X	X
10	5	18100-106C	O-RING	X	X
11	2	18100-107C	O-RING	X	X
12	1	18100-108C	O-RING	X	X
13	1	18100-109B	O-RING	X	X
14	2	18402-001	RETAINER RING, EXT	X	
15	1	18100-001C	O-RING	X	X
16	1	12116	COMPRESSION SPRING		
17	1	18100-110C	O-RING	X	X
18	1	12227	NAME TAG		
19	2	21082-002	SCREW, DRIVE		
20	1	22903	SPRING NUT		
21	1	11755	COTTER PIN, 5/64 X 3/4 SS	X	
22	1	23701	SPRING ROD		
23	1	18110-210T	BACKUP RING	X	X
24	1	18110-223T	BACKUP RING	X	X
25	A/R	25822	ANTI SEIZE		
26	1	25822-1	ANTI SEIZE	X	X

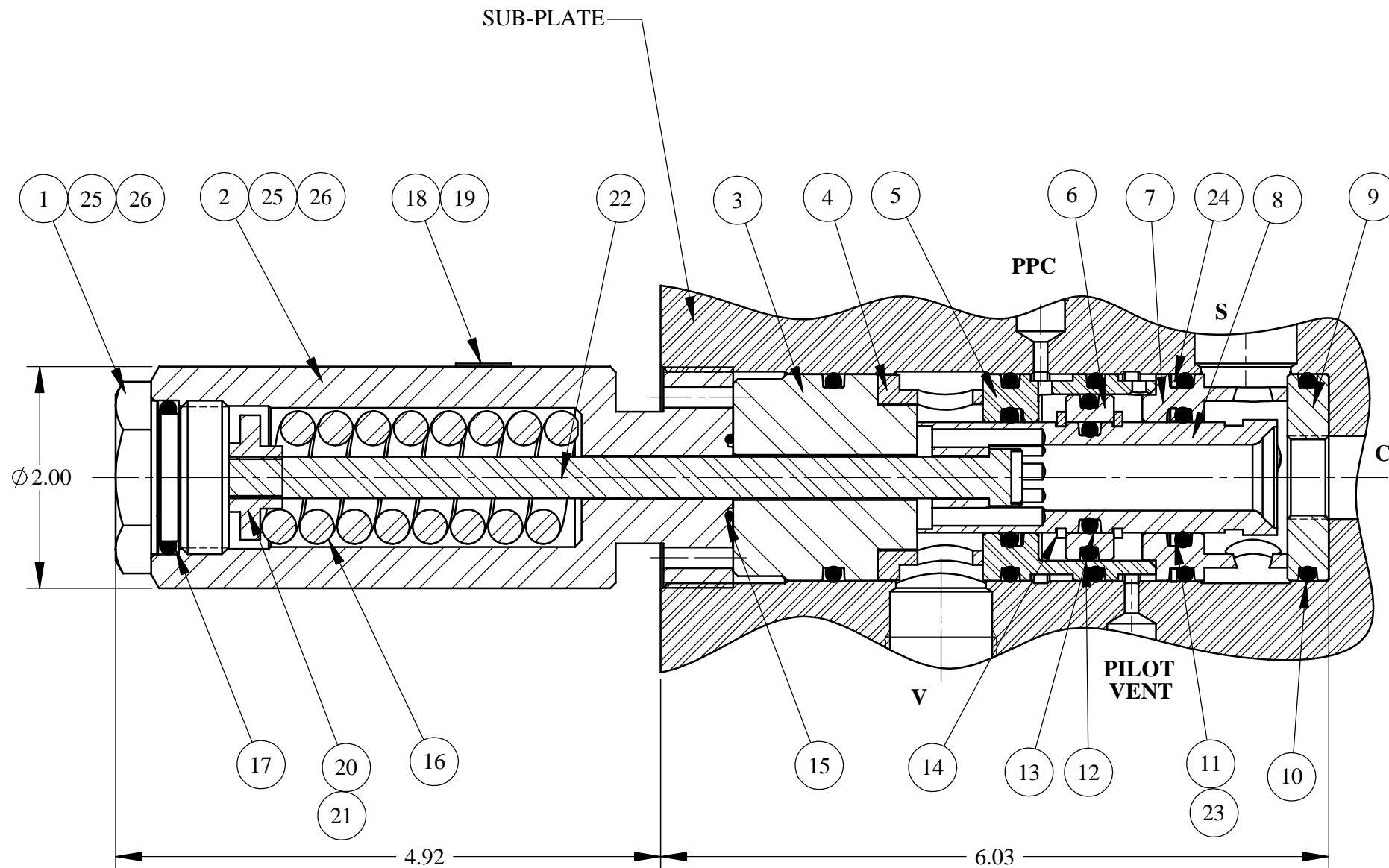

WORKING PRESSURE:

SUPPLY, S=5,000 PSI
 CYLINDER, C=5,000 PSI
 PILOT PRESSURE, PPC=1,500 - 3,000 PSI
 VENT PRESSURE, V=5,000 PSI
 DEPTH=10,000 FT

MATERIAL

STAINLESS STEEL
 INCONEL X-750
 17-4 PH
 N60
 N50
 DELRIN
 BUNA-N
 TEFLON

APPROX. WEIGHT: 5.5 LBS

SCHEMATIC

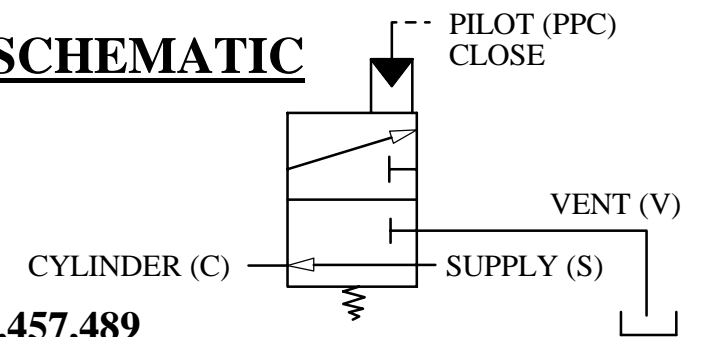

PAT NO. 4,457,489

NOTES: 1. SPECIAL TOOL 11520 USED ON ITEM #9.
 SPECIAL TOOL 11572 USED ON ITEM #14
 SPECIAL TOOL 22156 USED ON ITEM #8
 SPECIAL TOOL 11359 USED ON ITEM #20

MATERIAL SEE INDIV. BOM ITEMS	UNLESS OTHERWISE SPECIFIED TOLERANCES: DECIMALS FRACTIONS ANGLES .X ±.1 ± 1/32 ±1° .XX ±.01 .XXX ±.005	DRWN BY JOSE'	DATE 2/19/02	GILMORE VALVE CO. 1231 LUMPKIN RD. HOUSTON, TX. 77043 NORMALLY OPEN 3/4 SPM VALVE WITH CAPTURED VENT		
TREATMENT	CONDITION	CHKD BY WRC	DATE 2/22/02			
PROC. NO.	DEBURR BREAK SHARP EDGES .010 INTERNAL RADIUS .015 FINISH 63	APPD BY TBT	DATE 2/25/02			
THE INFORMATION CONTAINED IN THIS DRAWING IS THE SOLE PROPERTY OF GILMORE VALVE CO. UNLESS OTHERWISE STATED. ANY REPRODUCTION IN PART OR WHOLE WITHOUT THE WRITTEN PERMISSION OF GILMORE VALVE CO. IS PROHIBITED.	DIMENSIONS ARE IN INCHES DO NOT SCALE DRAWING INTERPRET DIM. & TOL. PER ASME Y14.5M - 1994	ERN NO. 00586	DATE 2/15/02			
				SIZE B	DWG NO. 22900-3	REV A
		SCALE 1:1		SOLIDWORKS		SHEET 1 OF 1