

REV	ECN/ERN NO.	DRWN	CHKD	APPD
A	ERN 00857	JOSE' 1/22/04	DJW 2/3/04	TBT 2/11/04

ITEM NO.	QTY.	PART NO.	DESCRIPTION	RK	SK
1	1	33055	BODY, 1-1/2"		
2	1	27122-1	SEAL	X	X
3	1	23093	SEAL SLEEVE	X	
4	1	27140	CAGE		
5	1	23089	FLANGE		
6	1	23095	PISTON		
7	1	23091	PILOT FLANGE		
8	2	23090	FLANGE 1-1/2" NPT		
9	2	18100-104C	O-RING	X	X
10	1	18100-066C	O-RING	X	X
11	1	18100-078B	O-RING	X	X
12	2	18110-131T	BACKUP RING	X	X
13	2	18100-115C	O-RING	X	X
14	2	18100-117C	O-RING	X	X
15	24	18224-003	S.H.C.S., 3/8-16 UNC X 1-1/2		
16	4	21053	H.H.C.S., 5/8-18 UNF X 1-5/8		
17	1	12000	SPRING, COMPRESSION		
18	1	12225	NAME TAG		
19	2	21082-002	SCREW, DRIVE		
20	A/R	25822	ANTI SEIZE		
21	2	25822-1	ANTI SEIZE	X	X

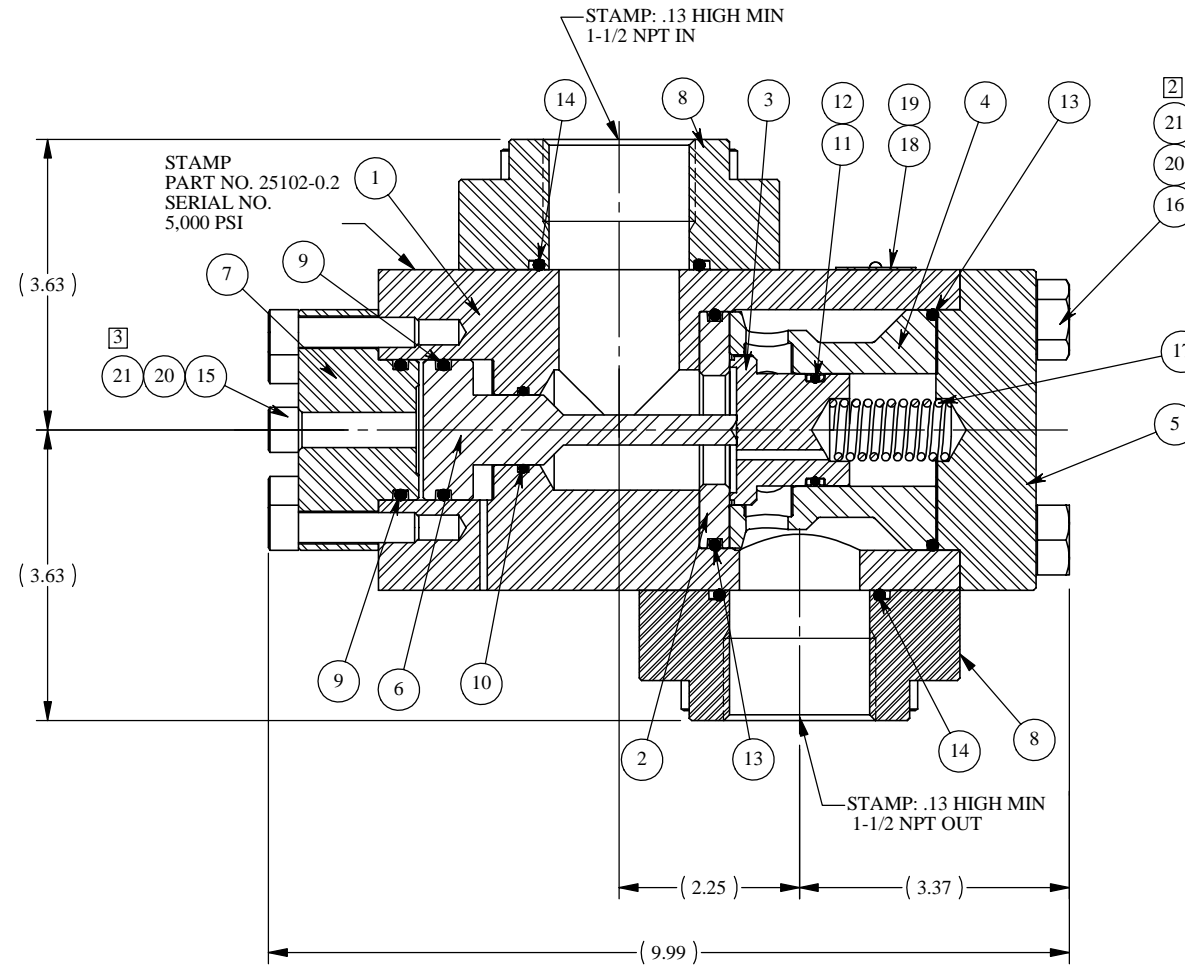

SECTION 'A-A'

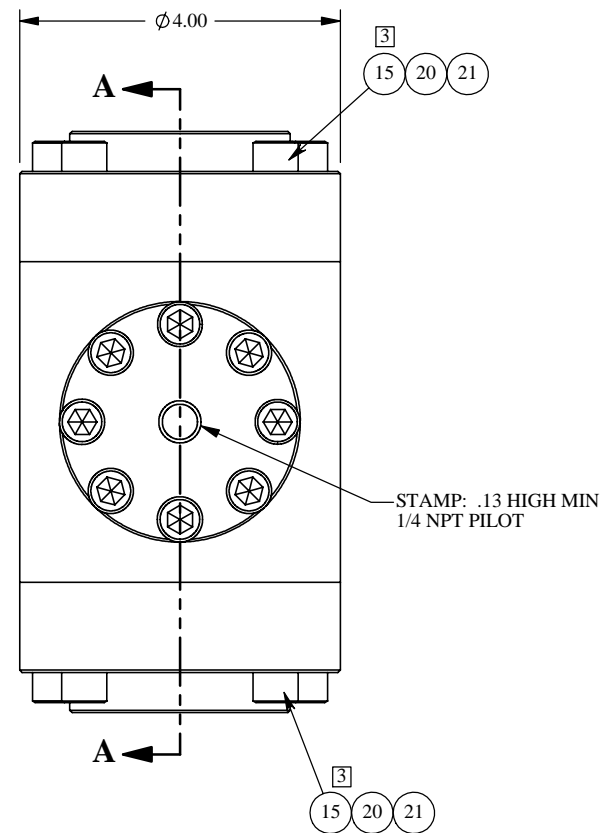
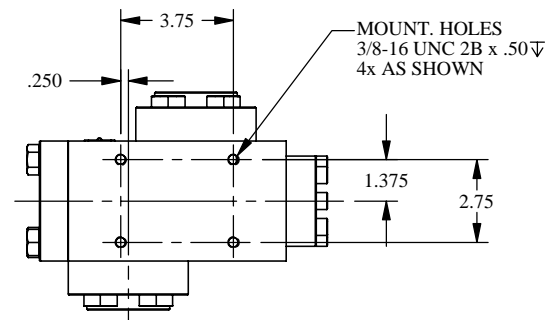

**MOUNTING DETAIL
BACK OF VALVE**

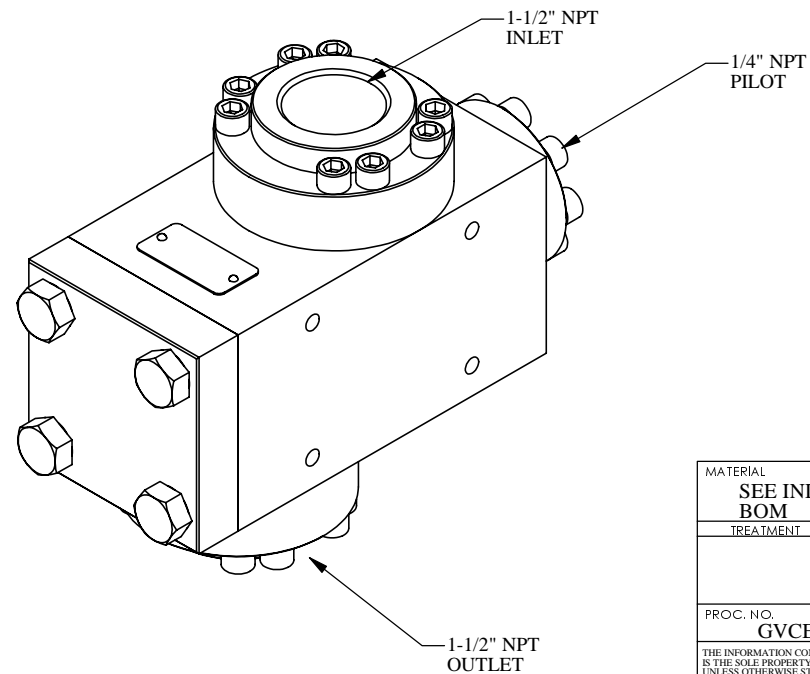

PRESSURE DATA

MAXIMUM PRESSURE - 5,000 PSI
 PROOF PRESSURE - 7,500 PSI
 CRACKING PRESSURE - 40 PSI
 PILOT PRESSURE/OUTLET RATIO - 1:4
 PILOT VENT - EXTERNAL

FLOW DATA

MAXIMUM FLOW CAPACITY - 320 GPM
 Cv = 30
 FLUIDS - WATER, AND MINERAL OIL
 BASED HYDRAULIC FLUID

PORTS

INLET - 1-1/2" NPT
 OUTLET - 1-1/2" NPT
 PILOT - 1/4" NPT

GENERAL DATA

TEMPERATURE RANGE - +32°F TO +200°F
 APPROX WEIGHT - 41 LBS
 FIELD SERVICEABLE

MATERIALS

STAINLESS STEEL
 DELRIN
 NITRILE RUBBER

U.S. PATENT NO. 4,793,590

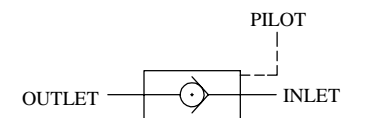

SCHEMATIC

NOTES:
 3. TORQUE PILOT FLANGE BOLTS (ITEM 15) TO 18 FT-LBS.
 2. TORQUE MAIN FLANGE BOLTS (ITEM 16) TO 108 FT-LBS.
 1. X DEPICTS PARTS IN REPAIR KIT 25102-0.2 RK/SK.

MATERIAL SEE INDIV BOM	TOLERANCES: DECIMALS FRACTIONS ANGLE X ± .1 ± 1/32 ± 1° XX ± .01 XXX ± .005 DEBURR BREAK SHARP EDGES .010 INTERNAL RADIUS .015 FINISH 68/	DRWN BY JOSE'	DATE 1/22/04	GILMORE VALVE CO. 1231 LUMPKIN RD. HOUSTON, TX. 77043 VALVE, CHECK, PILOT OPERATED, 1-1/2" NPT
TREATMENT	CONDITION	CHKD BY DJW	DATE 2/3/04	
PROC. NO. GVCEP-0418-T		APPD BY TBT	DATE 2/11/04	
<small>THE INFORMATION CONTAINED IN THIS DRAWING IS THE SOLE PROPERTY OF GILMORE VALVE CO. UNLESS OTHERWISE STATED, ANY REPRODUCTION IN PART OR WHOLE WITHOUT THE WRITTEN PERMISSION OF GILMORE VALVE CO. IS PROHIBITED.</small>		ERN NO. 00857	DATE 1/13/04	
<small>DIMENSIONS ARE IN INCHES DO NOT SCALE DRAWING INTERPRET DIM. & TOL. PER ASME Y14.5M - 1994</small>		SIZE C	DWG NO. 25102-0.2	REV A
SCALE NTS		SOLIDWORKS		SHEET 1 OF 1